

[www.red-aircraft.com](http://www.red-aircraft.com)

**RED** Aircraft

# ENGINE MANUFACTURER AND DESIGN ORGANISATION

## Home of the



## V12

### History

Raikhlin aircraft Engine Developments GmbH - RED Aircraft®- is active in complex engine technology since 1995.

The focus changed in 2008 to high performance compression engines for the aviation industry.

The A03 V12 engine is our own clean sheet development with a very high level of vertical integration.

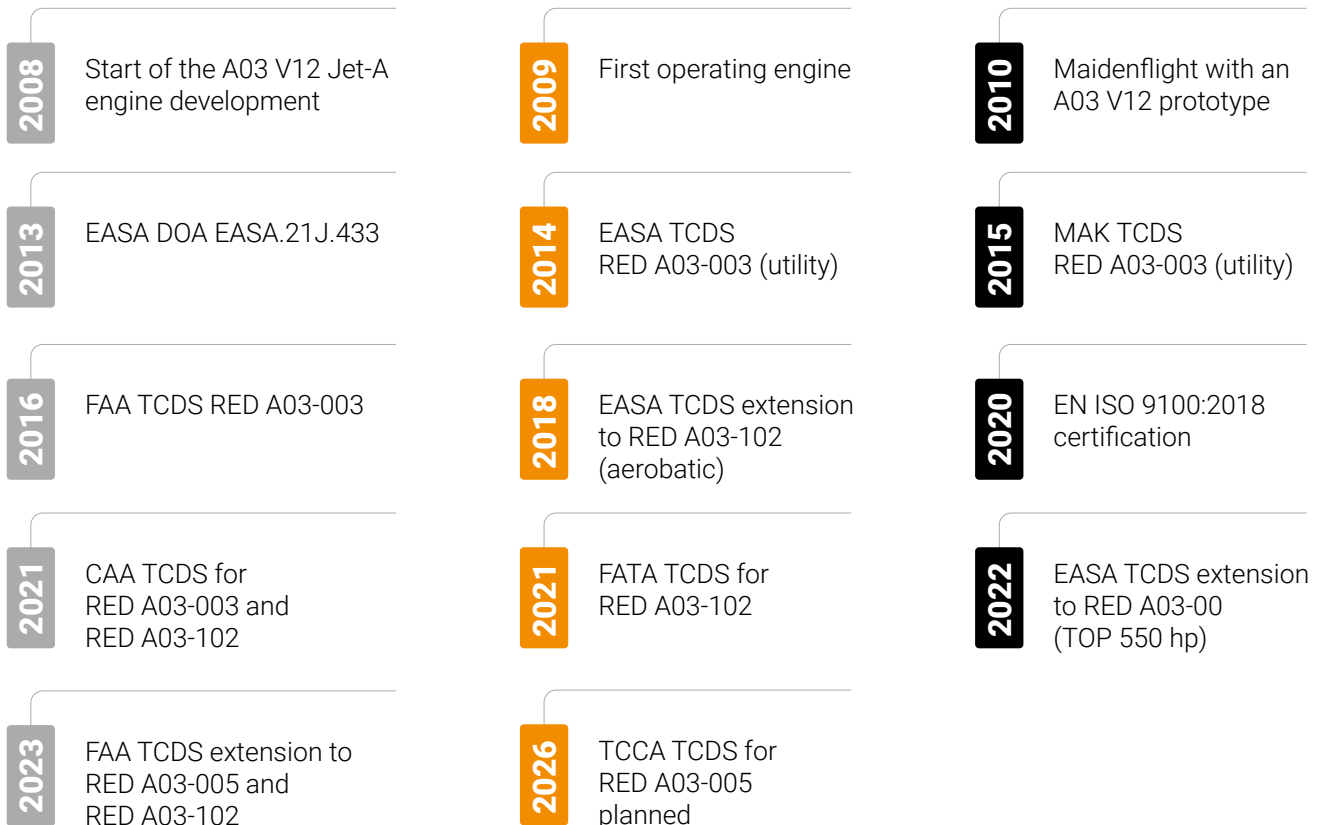



## RED V-ENGINE FAMILY OVERVIEW



**RED A03-003**  
Regular Gearbox  
non-inverted ops.



**RED A03-102**  
Gearbox for  
Aerobatic Capability  
+9g / -7g

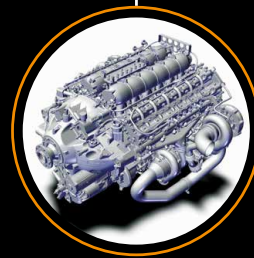

**RED A03-200**  
High Altitude  
Configuration FL500



**RED A03-300**  
w/o Gearbox, for  
Helicopter, Airship,  
Generators & APUs

## RED A03 V12 BENEFITS

- Designed for **Aviation**
- Type **Certified** Diesel Engines
- Parallel & Serial Hybrid / **APU** Experience
- Best Fuel Efficiency **218 g/kWh**
- **SAF** approved
- **Single** Lever Operation
- **Down-Sizing** V8 / I6 / I4 foreseen
- **Redundancy** - independent cylinder banks
- FADEC **DAL B** - Development and IP inhouse
- Production **90% inhouse**



# PERFORMANCE DATA RED A03-003 / -005 ENGINE

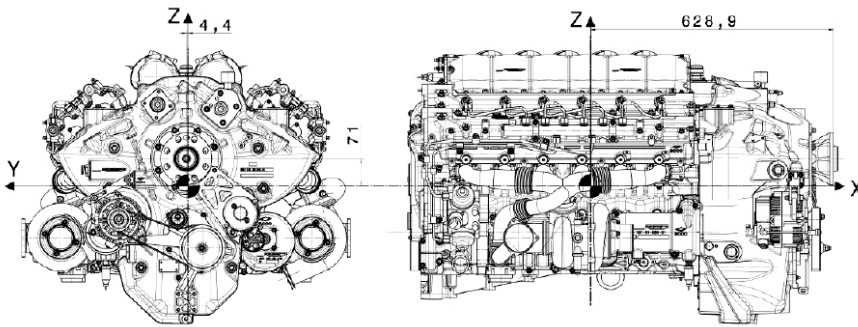

## DIMENSIONS

WIDTH	850 mm
HEIGHT	712 mm
LENGTH	1114 mm

## TECHNICAL DATA

Take-Off Power (TOP) Take-Off Propeller Speed	368 kW (500 HP) 2127 1/min	405 kW (550 HP) 2127 1/min
Max. Continuous Power (MCP) Max. Continuous Propeller Speed	338 kW (460 HP) 1995 1/min	
Pressure altitude	2000 m	
BSFC (Optimum)	218 g/kWh	
Fuel consumption: Take Off Power	90 kg/h	100 kg/h
Max. Cont. Power	78 kg/h	78 kg/h
@ 294 kW (400 hp)	66 kg/h	66 kg/h
@ 220 kW (300 hp)	49 kg/h	49 kg/h

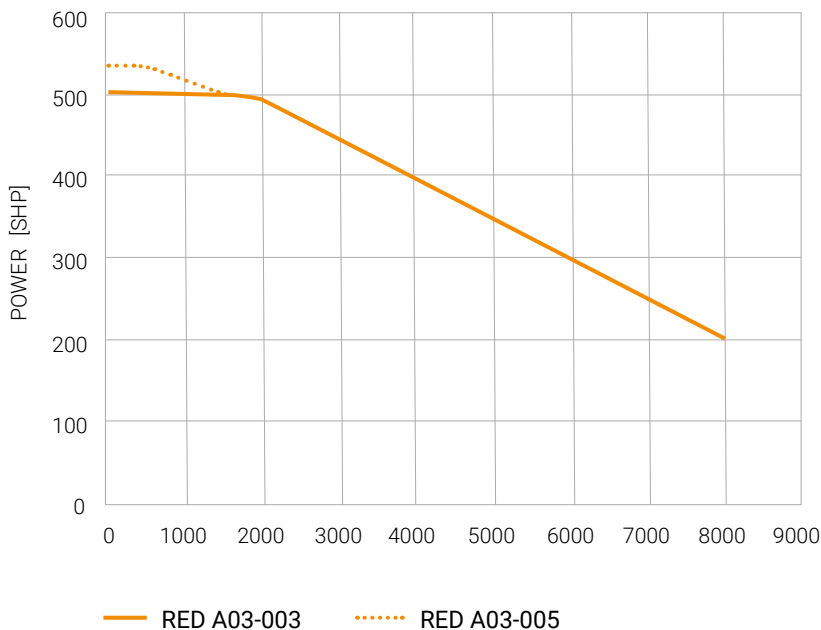

# KEY FEATURES

## RED A03 – FADEC

Full authority digital engine control

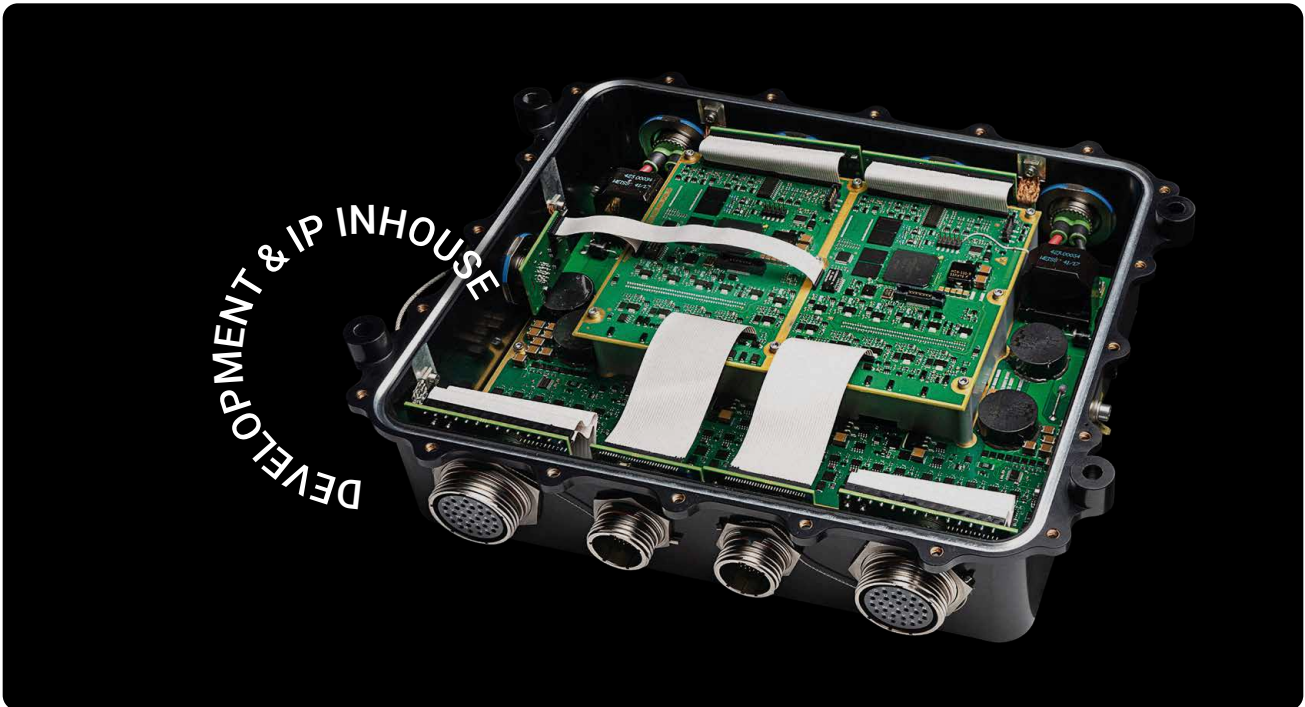

**The RED A03 engine is controlled with a fully redundant Engine Control Unit**



### Certification / Safety Standard

- Development according to civil aviation standards RTCA **DO-178C** (software) and **DO-254** (hardware).
- Design Assurance Level: **DAL B**.
- Certified for environmental conditions according to civil aviation standards RTCA **DO-160G** for CS-23/CS-27 and CS-29 applications.



**Single Power Control Lever operation to minimize pilot workload**



### Extensive Diagnostic functions and Communication interface options

- IBIT (Initial Built-In Test) and CBIT (Continuous Built-In Test) enables failure detection and monitoring
- High speed (40Hz) and low-speed Data Logging (1Hz)
- Engine Usage and Failure Logging
- **Maintenance Interface** over CAN-Bus
- Cockpit/Display indication over RS 485 / RS 422 interface
- Bidirectional RS 485 enables un-manned engine control

# UTILITY AIRCRAFT FOR CROP DUSTING AND SKY DIVING



*Agricultural Aircraft:*  
**RED RDD LLC Air Tractor AT 301**

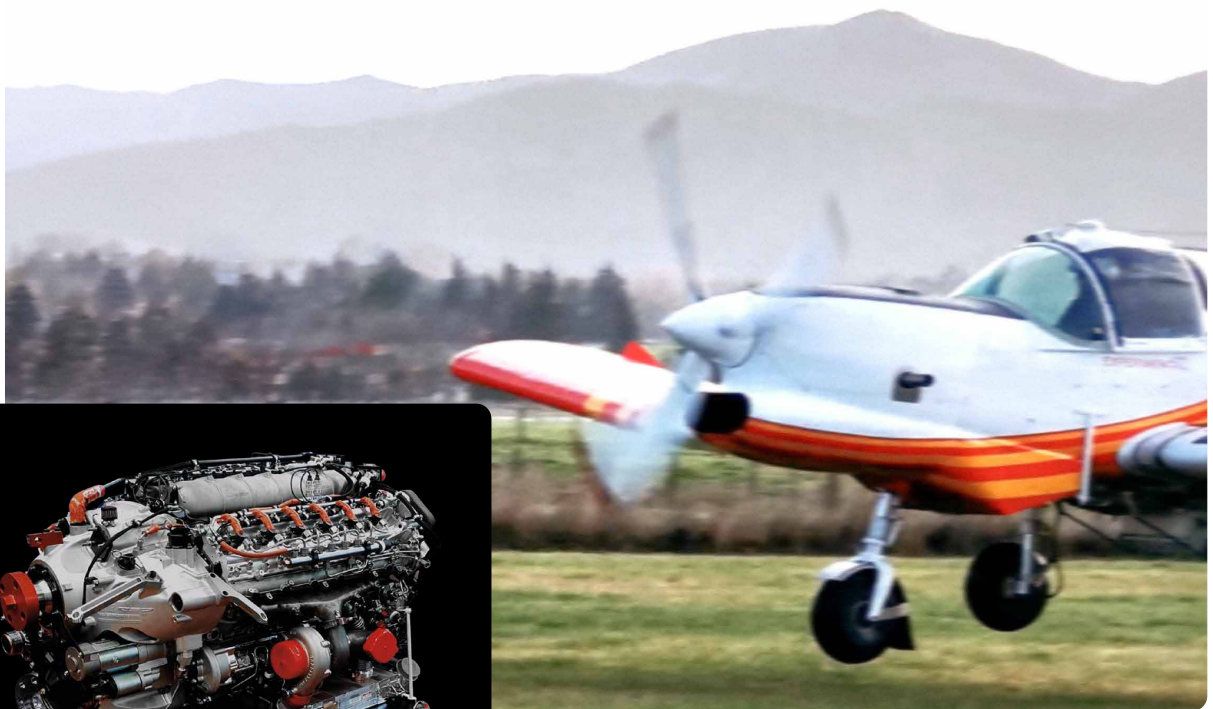

*Agricultural Aircraft:*  
**Diesel Air (NZ) STC Conversion**  
Fletcher FU-24 Crop Dusting & Sky Diving

# TRAINING, COMMUTER AND TOURING AIRCRAFT



photo credit: Robert Kobzey

Commuter Aircraft:

**Sealand Aviation Ltd. DHC-2 Beaver**

Replacing the R-985 Wasp Junior radial engine with RED A03-005 engine.

## RED AIRCRAFT SERVICES Your One-Stop-Shop

- 01 Engine & Spare Part Sales
- 02 Joint Engine Developments
- 03 Sourcing & Supplier Selection Support
- 04 Engineering & Integration Support / 3D Data
- 05 Testing & Compliance Showing Support
- 06 Documentation & Manual Creation



# MODERN PARALLEL HYBRID PROPULSION AND TRAINER



*Trainer Aircraft:*  
**Maloy Aircraft LLC MA-1 Blue Jay**



*Commuter & Cargo Aircraft:*  
**Ampaire Inc. ECO-Caravan**

Maiden flight in November 2022 using the RED A03-005 engine with 550HP plus electric motor & battery set in a parallel hybrid design to allow a system performance of 800HP.

# MODERN TOURING AND CARGO AIRSHIP



„Delivering an aircraft with

# 75%

**FEWER EMISSIONS** with red aircraft engines in comparison with similar sized aircraft with up to 130 passengers on comparable routes.“

**Hybrid Air Vehicles Ltd. Airlander 10**

# PERFORMANCE DATA HIGH ALTITUDE ENGINE RED A03-200

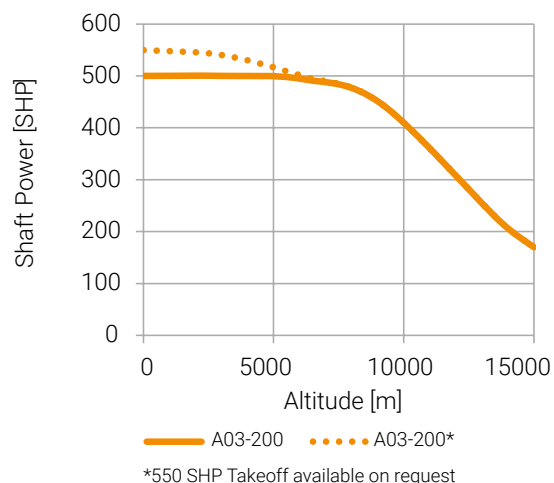
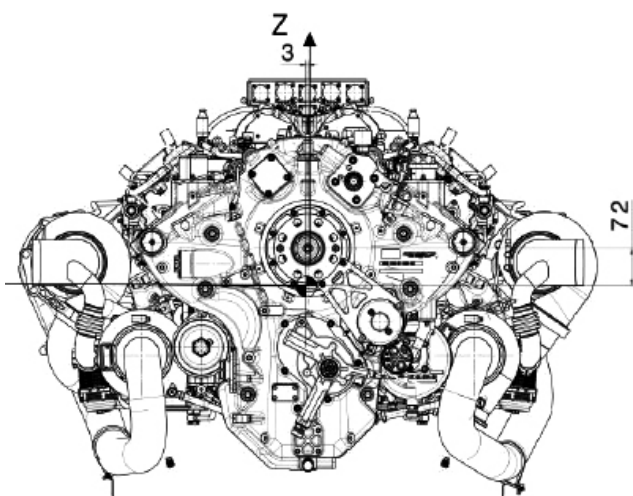

## ENGINE DESCRIPTION

NUMBER OF CYL. + ARRANGEMENT	V-12
FUEL TYPE	JET FUEL
DISPLACEMENT	6.1 L
BORE X STROKE	86 MM X 88 MM
VALVES PER CYLINDER	4
TURBO CHARGER	2 X TWIN STAGE
FUEL SYSTEM	COMMON RAIL
ELECTRICAL SYSTEM	2 X 28V 3.5KW ALTERNATOR
REDUCTION GEAR	1:1.88
DRY MASS	390 KG
FADEC	DESIGN ASSURANCE LEVEL B CERTIFIED IN COMPLIANCE TO RTCA DO-254, DO-178C & DO-160G

## Key Operational Features

- Developed for very high altitude operation up to 15 km FL500
- MCP rating - 460 SHP at FL250
- High altitude restart capability
- Digital FADEC for unmanned operation

## PERFORMANCE & RATINGS

TAKEOFF POWER	500 SHP	550* SHP
TAKEOFF PROPELLER SPEED	2127 RPM	
MAXIMUM CONTINUOUS POWER	460 SHP	
MAXIMUM CONTINUOUS SPEED	1995 RPM	
BSFC (BEST)	215 G/KWH	
FUEL FLOW:		
AT TAKE-OFF	85 KG/H	
AT MCP	77 KG/H	
AT 400 HP	65 KG/H	
AT 300 HP	47 KG/H	

## Design Features

- Operates with Jet Fuel
- High safety level with independent circuits for each engine bank:
- Air induction system
- Fuel system
- Cooling system
- FADEC single lever engine control
- Twin Stage turbocharged
- Self-carrying structure for cantilever installation
- Dry-sump oil system
- Integrated engine oil and gearbox oil tank.
- Integrated engine oil and gearbox oil heat exchanger
- Designed for lean maintenance

# PERFORMANCE DATA AEROBATIC ENGINE RED A03-102

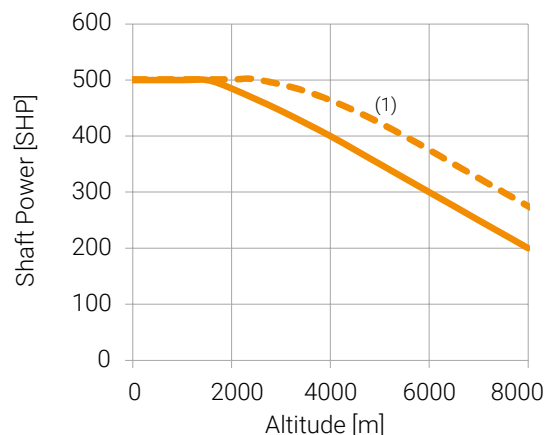
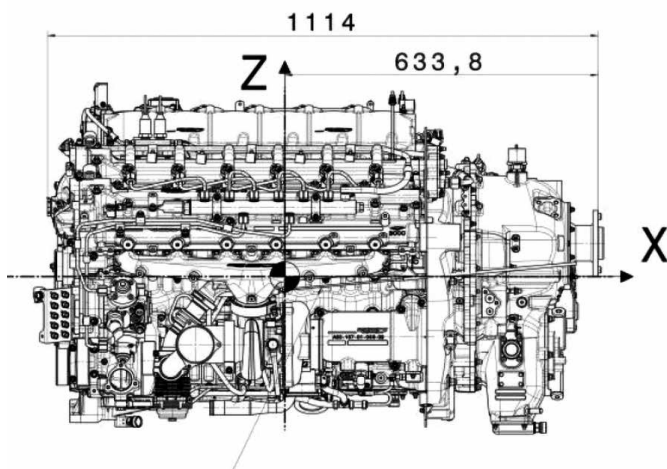

(1) Enhanced altitude performance available on request (dotted line).  
(2) 550 SHP Takeoff available on request.

## DIMENSIONS

WIDTH	850 mm
HEIGHT	712 mm
LENGTH	1114 mm

## ENGINE DESCRIPTION

NUMBER OF CYL. + ARRANGEMENT	V-12
FUEL TYPE	JET FUEL
DISPLACEMENT	6.1 L
BORE X STROKE	86 MM X 88 MM
VALVES PER CYLINDER	4
TURBO CHARGER	SINGLE STAGE
FUEL SYSTEM	COMMON RAIL
ELECTRICAL SYSTEM	28V 3.5KW ALTERNATOR
REDUCTION GEAR	1:1.88
DRY MASS*	357 KG
FADEC	DESIGN ASSURANCE LEVEL B CERTIFIED IN COMPLIANCE TO RTCA DO-254, DO-178C & DO-160G

\* According to type design configuration

## Key Operational Features

### CERTIFIED FOR

- +9g positive load factor
- -7g negative load factor
- Inverted flight operation
- Aerobatic maneuvers

## Key Design Features

- Operates with Jet Fuel
- High safety level with independent circuits for each engine bank:
- Air induction system
- Fuel system
- Cooling system
- FADEC single lever engine control
- Turbocharged
- Self-carrying structure for cantilever installation
- Dry-sump oil system
- Designed for lean maintenance

## Certification

Certified in compliance to  
EASA CS-E / TYPECERTIFICATE-  
DATA-SHEET No.:

E.150.

# RED A03 **Hybrid** Generator Units



- Hybrid Electric / **Genset**
- **eVTOL** & electric Aircraft
- Auxiliary Power Unit **APU**
- **Less CO<sub>2</sub>** emission
- **Less noise** emission
- **Lower operating cost**

Am alten Wehr 23 53518 Adenau - Germany  
Phone: +49 (0) 2691/937 76-0  
FAX.: +49 (0) 2691/937 76-31  
info@red-aircraft.com

[www.red-aircraft.com](http://www.red-aircraft.com)

